

36" Restaurant Range Series



Model IR-6



Burner heads remove for easy cleaning.

Restaurant Range Features

- Stainless steel front, sides, backguard, shelf, landing ledge and kick plate.
- Welded stainless steel seams.
- Large 5" (127) stainless steel landing ledge.
- 6" (152) heavy duty legs with adjustable feet.
- One year parts and labor warranty.
- AGA and CGA design certified, NSF and CE listed.



Model Numbers

- | | | | |
|---------------------------------------|--------------------------------------|--------------------------------------|------------------------------------|
| <input type="checkbox"/> IR-6 | <input type="checkbox"/> IR-4-G12 | <input type="checkbox"/> IR-2-G24 | <input type="checkbox"/> IR-G36 |
| <input type="checkbox"/> IR-6-C | <input type="checkbox"/> IR-4-G12-C | <input type="checkbox"/> IR-2-G24-C | <input type="checkbox"/> IR-G36-C |
| <input type="checkbox"/> IR-6-XB | <input type="checkbox"/> IR-4-G12-XB | <input type="checkbox"/> IR-2-G24-XB | <input type="checkbox"/> IR-G36-XB |
| <input type="checkbox"/> IR-4-RG12 | | <input type="checkbox"/> IR-4-S18 | |
| <input type="checkbox"/> IR-4-RG12-C | | <input type="checkbox"/> IR-4-S18-C | |
| <input type="checkbox"/> IR-4-RG12-XB | | <input type="checkbox"/> IR-4-S18-XB | |

Cooktop - Open Burner Features

- PyroCentric™ burner heads with two rings of flame for even cooking no matter the pan size.
- PyroCentric burners are 28,000 BTU/hr (8 KW) with a 7,000 BTU/hr. (2 KW) low simmer feature.
- Cast iron burners are anti-clogging and removable for easy cleaning.
- No gaskets or screws.
- Grates are in 12" x 12" (305 x 305) sections to easily lift off for cleaning.
- Anti-clogging shield designed in the grate protects the pilot from grease and debris.
- Pots slide easily from section to section.

Standard Oven Features

- Chef depth standard oven interior accommodates standard 18" x 26" (457 x 660) sheet pans front-to-back and side-by side. Interior is 26¹/₂" w x 26" d x 14" h (673 w x 660 d x 356 h).
- 100% safety pilot.
- Oven controls located on the side in cool zone.
- Manual oven shut-off valve.
- Heavy duty thermostat with temperature range from 150°F to 500°F. (65°C to 260°C).
- Porcelainized side, rear, deck and door lining.
- Unique baffle above the burner distributes heat flow to provide even cooking temperatures throughout the 35,000 BTU/hr. (10 KW) oven.
- Stamped inner door liner provides extra strength while optimizing heat retention.

Convection Oven Features (add suffix C)

- Convection oven with 1/4 hp blower motor is optional, cooks products faster and evenly with less shrinkage.
- Convection oven interior dimensions 26¹/₂" w x 22¹/₂" d x 14" h (673 w x 572 d x 356 h).
- Three position switch for cooking or cool down.
- Burner "ON" indicator light and one hour manual timer. Fan shuts off automatically when door is open.

All measurements in () are metric equivalents.

Imperial 36" (914) Restaurant Range Series

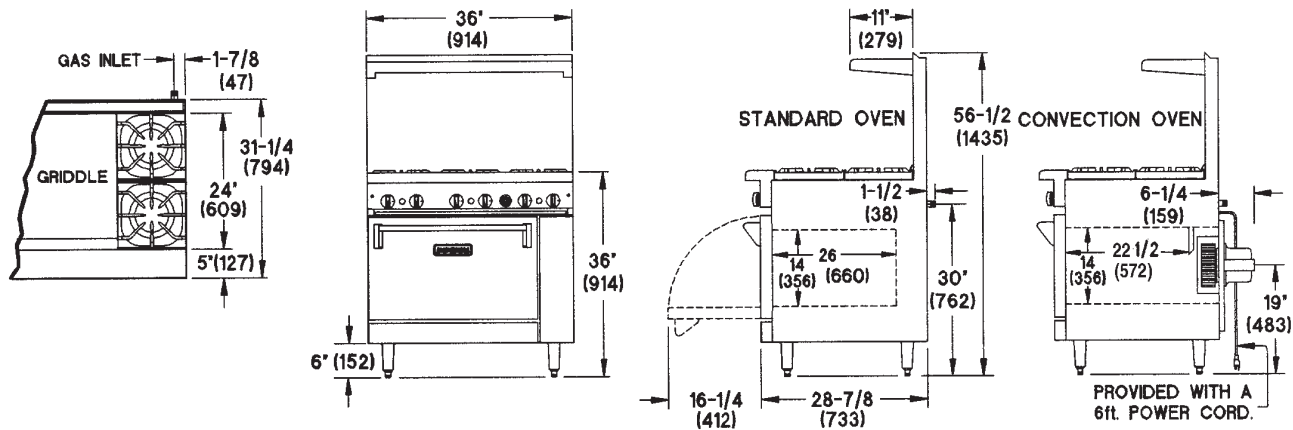

Specification #:

Model#	Description	Total BTU	Total (KW)	Ship Weight (Kg.)	Lbs.
IR-6	6 Open Burners, 1 Standard Oven	203,000	(60)	(274)	605
IR-6-C	6 Open Burners, 1 Convection Oven	198,000	(58)	(301)	665
IR-6-XB	6 Open Burners, 1 Cabinet Base	168,000	(49)	(246)	545
IR-4-G12	4 Open Burners, 12" (305) Griddle, 1 Standard Oven	167,000	(49)	(283)	625
IR-4-G12-C	4 Open Burners, 12" (305) Griddle, 1 Convection Oven	162,000	(47)	(310)	685
IR-4-G12-XB	4 Open Burners, 12" (305) Griddle, 1 Cabinet Base	132,000	(39)	(256)	565
IR-2-G24	2 Open Burners, 24" (610) Griddle, 1 Standard Oven	131,000	(38)	(288)	635
IR-2-G24-C	2 Open Burners, 24" (610) Griddle, 1 Convection Oven	126,000	(37)	(314)	695
IR-2-G24-XB	2 Open Burners, 24" (610) Griddle, 1 Cabinet Base	96,000	(28)	(260)	575
IR-G36	36" (914) Griddle, 1 Standard Oven	95,000	(28)	(297)	655
IR-G36-C	36" (914) Griddle, 1 Convection Oven	90,000	(26)	(319)	705
IR-G36-XB	36" (914) Griddle, 1 Cabinet Base	60,000	(17)	(269)	595
IR-4-RG12	4 Open Burners, 12" (305) Raised Griddle, 1 Standard Oven	167,000	(49)	(283)	625
IR-4-RG12-C	4 Open Burners, 12" (305) Raised Griddle, 1 Convection Oven	162,000	(47)	(310)	685
IR-4-RG12-XB	4 Open Burners, 12" (305) Raised Griddle, 1 Cabinet Base	132,000	(39)	(256)	565
IR-4-S18	4 Extra Wide Open Burners, 1 Standard Oven	147,000	(43)	(272)	600
IR-4-S18-C	4 Extra Wide Open Burners, 1 Convection Oven	142,000	(42)	(298)	660
IR-4-S18-XB	4 Extra Wide Open Burners, 1 Cabinet Base	112,000	(33)	(244)	540

Range Dimensions: 36" (914) w x 37 1/2" (953) d x 36" (914) h. Height to cooking surface.

Crated Dimensions: 38 1/2" (978) w x 39" (991) d x 35" (889) h. All measurements in () are metric equivalent.

Standard Exterior Specifications

Front, sides, landing ledge, control panel, backguard with shelf and kick plate shall be constructed of stainless steel with welded and finished stainless steel seams. Control knobs shall be constructed of durable cast metal, polished chrome finish. Chrome plated 6" (152) legs shall have adjustable feet.

Cooktop Specifications

Open burners shall be 28,000 BTU/hr. (8 KW) lift-off PyroCentric™ burner heads with no gaskets, no screws. Each burner shall have one standing pilot. Drip tray shall be one piece and removable. Top grates shall be constructed in 12" x 12" (305 x 305) lift-off sections of heavy-duty cast iron. A cast-in bowl shall direct heat upward. Top grate design shall include an integrated pilot shield. Griddle tops shall have a highly polished 3/4" (19) plate with 3" (76) wide stainless steel grease trough and be located on the left side of the range top. A 20,000 BTU/hr. (6 KW) burner shall be located every 12" (305) of griddle surface. Manual controls shall be standard, thermostatic controls optional. Raised griddle with broiler shall be available in 12", 24" and 36" (305, 610, 914) widths with 3/4" (19) plate and manual control only and located on right side of range top. Burner shall be 20,000 (6 KW) BTU/hr. output with a heat deflector every 12" (305). Large griddle grease can, large full width broiler drip tray and one removable chrome plated broiler rack shall be included.

Standard Oven Specifications

Oven shall be 12 gauge construction with a welded front frame. Oven shall be fully insulated with non-sag fiberglass. Oven interior shall have porcelainized sides, rear, deck and door lining. Oven burner shall provide 35,000 BTU/hr. (10 KW). Unique baffle above the burner shall distribute heat flow to provide even cooking temperatures throughout the oven.

Standard Oven Specifications continued

Oven shall have a 100% safety pilot. One heavy duty locking chrome plated rack shall be included. Thermostat shall be adjustable from 150°F to 500°F (65°C to 260°C) Oven interior dimensions shall be 26 1/2" w x 26" d x 14" h (673 x 660 x 356).

Convection Oven Specifications

Shall have same exterior as standard oven. 1/4 HP, 1725 RPM blower motor (120VAC-60 HZ - 1Ph) with 5 amp draw. a 3-prong 6" (1829mm) power cord shall be provided. Output shall be 30,000 BTU/hr. (9 KW) with "U" burner and electronic ignition. Unit shall include three heavy duty chrome plated racks supported by chrome plated guides. Unit shall include three-position switch for cooking or cool down, a burner "on" indicator light and one hour manual timer. Thermostat shall be adjustable from 150°F to 500°F. Oven interior dimensions shall be 26 1/2" w x 22 1/2" d x 14" h (673 x 572 x 356).

Gas: Manifold pressure is 5.0" W.C. for natural gas or 10.0" for propane gas. Manifold size 3/4" (19) NPT. 3/4" (19) pressure regulator supplied with equipment to be installed at time of connection. Specify type of gas and elevation if over 2000 ft. (610 m).

Clearance: For use only on non-combustible floors. Legs or casters are required for non-combustible floors; or 2" (51) overhang is required when curb mounted. Provide 0" clearance from non-combustible surfaces and 8" (203) from combustible surfaces.

Optional Items: ■ Extra chrome rack ■ Reinforcement channels for mounting cheese melter/salamander ■ 10" (254) stainless steel wok ring ■ Saute burner head ■ Wok burner head ■ 220V motor and transformer ■ Extra oven racks ■ Thermostatic griddle control (specify griddle size) ■ Grooved griddle top ■ Chrome griddle top ■ Griddle safety valve ■ Gas shut off valve 3/4" (19) ■ Quick disconnect and flexible gas hose ■ 6" (152) casters

AIA File #:

Imperial Commercial Cooking Equipment

1128 Sherborn Street ■ Corona, CA 92879 ■ 800.343.7790 ■ Ph: 951.281.1830 ■ Fx: 951.281.1879

www.imperialrange.com ■ E-mail: imperialsales@imperialrange.com