



Follow the Leader™

Floral • Deli • Seafood • Meat • Bakery • Produce • Front End

INTRODUCING

UNISOURCE HEAVY DUTY MODENA & VENICE

ARTISAN BREAD SLICERS



- Fully automatic slicers
- Heavy duty construction
- Slices soft or heavy breads
- Includes heavy duty castor wheels and crumb drawer
- One year parts/labor warranty
- 24/7 Nationwide Service

Phone: (888) 443-8782 • Fax: (516) 681-0845 • email: info@unisourcefoodequipment.com • www.unisourcefoodequipment.com
56 Rockland Drive, Jericho NY 11753



Tilt the front cover open and you will discover a clever removable crumb collector with a large capacity. With its perfect height, the tray can be emptied easily and in no time.

Due to an ingenious system allowing to fold back the bag opening blowing device, the Venice can easily be stored, even when fitted with this accessory.

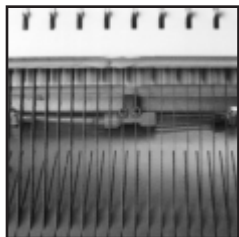

The "M" versions of the Modena and Venice slicers, which are fitted with the JAC lubrication system as standard, can also be supplied with a "lubrication" kit as an option, allowing them to meet the most demanding requirements.

The standard Venice model features a safety sensor designed to protect the operator when positioning the loaves.

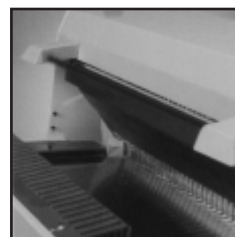

The digital screen tells the user when the blades should be replaced, and on version "M" machines, when the level of edible lubricant needs to be topped up.

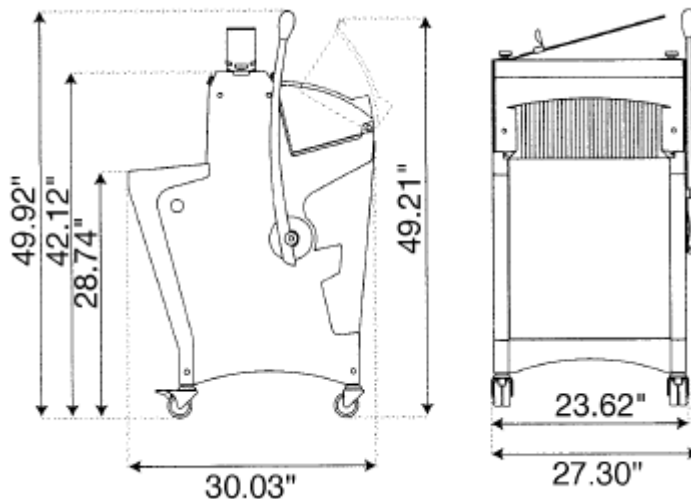

TECHNICAL SPECIFICATIONS

Modena/Venice	MODENA 450	MODENA 450M	VENICE 450	VENICE 450M
Max. loaf dimensions (L x w x h) (in cm)	17.16" X 12.48" X 6.24"	17.16" X 12.09" X 6.24"	17.16" X 12.48" X 6.24"	17.16" X 12.48" X 6.24"
Power output (in kW)	363 lbs.	385 lbs.	363 lbs.	385 lbs.
Net weight (in kg)	165	175	165	175
Choice of				
Slice thickness (in mm)	from 0.312" to 0.624"	from 0.351" to 0.429"	from 0.132" to 0.624"	from 0.351" x to 0.429"
Loaf height	low, normal, high	normal	low, normal, high	normal
Type of motor 208/220V	single- or 3-phase	3-phase	single- or 3-phase	single- or 3-phase
Options				
Height raised by 8 cm	•	•	•	•
Lubrication	•	•	•	•
Cover with automatic start-up	•	•	•	•
Bag opening blowing system			•	•