

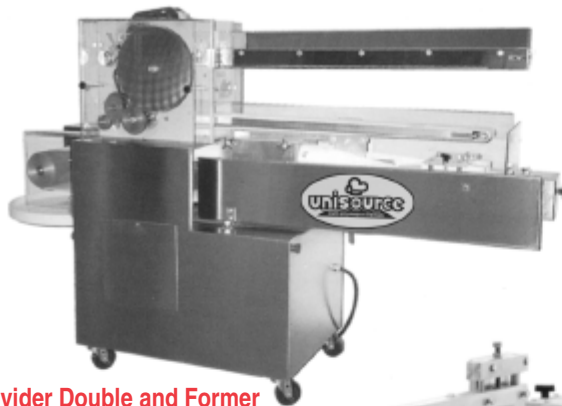

Follow the Leader™

Floral • Deli • Seafood • Meat • Bakery • Produce • Front End

INTRODUCING UNISOURCE HEAVY DUTY *Bagel-O-Matic*™ DIVIDERS AND FORMERS



Single Divider Double and Former
UNI-SS

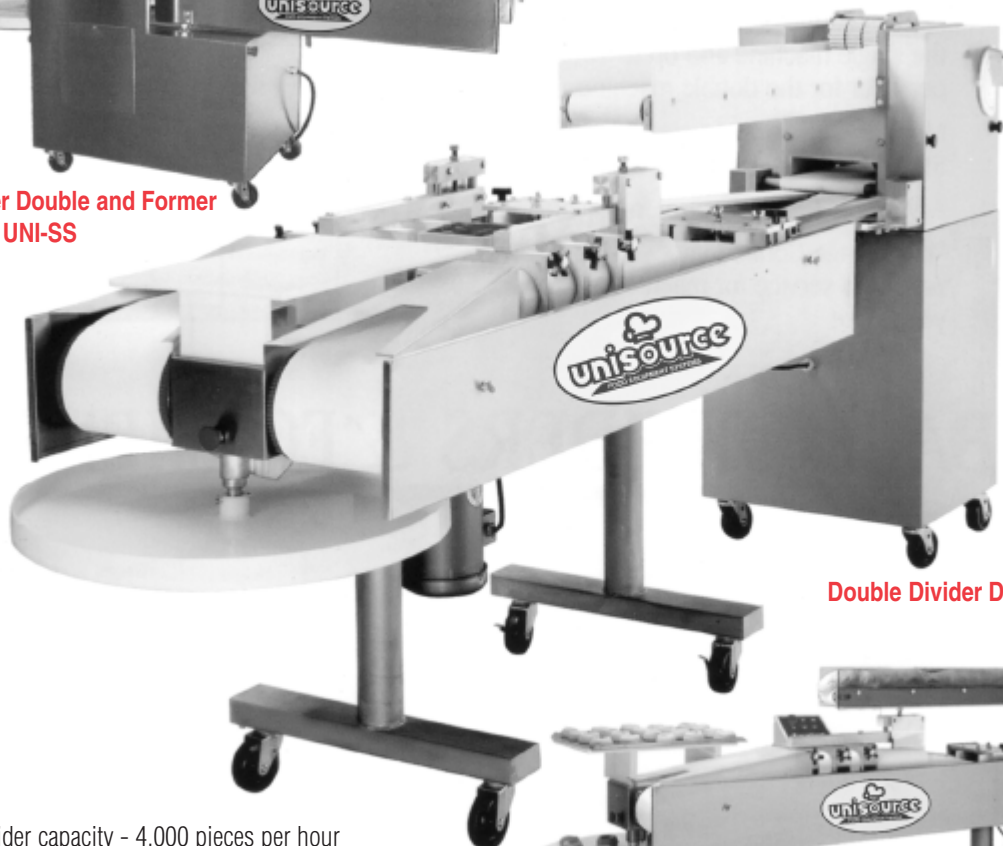

Double Divider Double Former



All Stainless Steel Single Divider & Former
UNI-SS-S

- Single divider capacity - 4,000 pieces per hour
- Double divider capacity - 10,000 pieces per hour
- Heavy duty construction
- Heavy duty caster wheels
- Low maintenance
- Easy to clean
- Adjustable speed control for divider
- One year parts/labor warranty
- 24/7 Nationwide Service

Phone: (888) 443-8782 • Fax: (516) 681-0845 • email: info@unisourcefoodequipment.com • www.unisourcefoodequipment.com
56 Rockland Drive, Jericho NY 11753

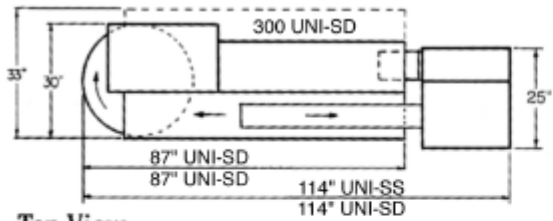

Top View

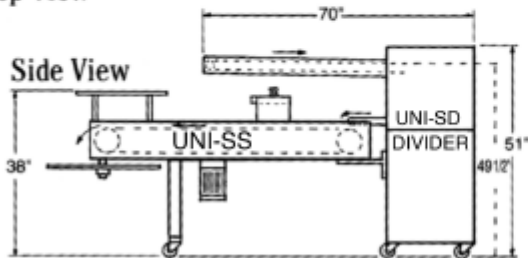

Side View

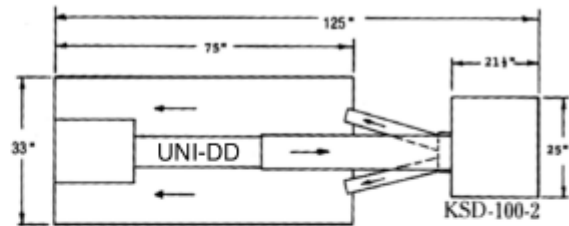

Top View

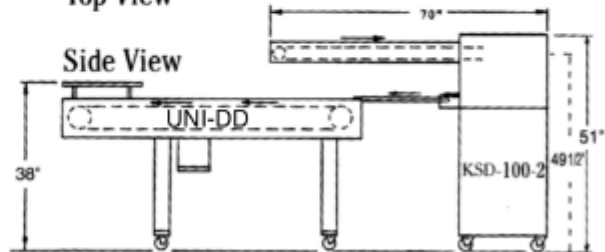

Side View

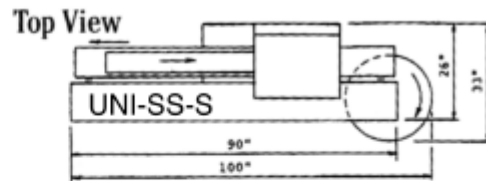

Top View

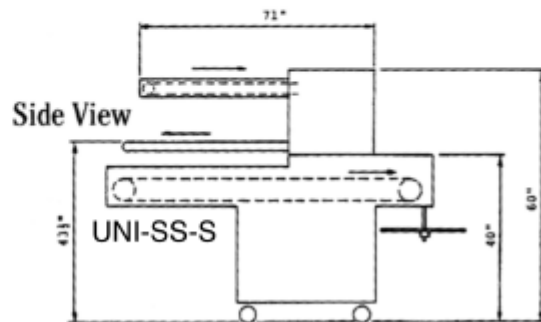

Side View



TECHNICAL SPECIFICATIONS

Model #	HP	Length	Width	Height	Weight	Capacity
UNI-SS Single Divider/Single Former	3/4 HP/1 HP	114	30	57	1000	300 dozen
UNI-SD Single Divider/Double Former w/Mini	3/4 HP/1 HP	114	33	57	1100	300 dozen
UNI-DD Double Divider/Double Former	1 HP/2 HP	125	33	57	1300	600 dozen
UNI-SS-S Single Divider/Single Former	3/4 HP/1 HP	90	33	57	1200	300 dozen