



Follow the Leader™

Floral • Deli • Seafood • Meat • Bakery • Produce • Front End

INTRODUCING THE UNISOURCE HEAVY DUTY BRAVO™ MINI-RACK ROTATING ELECTRIC OVEN

Features:

- Small foot print
- Fits standard 18" x 26" size pans
- 8 pan capacity
- Built in high capacity steam system
- Full height viewing glass in oven
- Built-in rotating rack for even bake
- Complete stainless interior and exterior
- Canopy w/factory supplied fan standard
- Single point flue connection
- Control panel features thermostat, bake and steam timers
- Internal baking chamber light
- One year parts/labor warranty
- 24/7 Nationwide Service
- Guaranteed bake even air flow system

Options:

- 6 pan capacity
- 10 pan capacity
- Proof box base
- Stand

Models:

- UNI-MRO-6E (6 pan oven)
- UNI-MRO-8E (8 pan oven)
- UNI-MRO-10E (10 pan oven)
- UNI-MRO-6EP (6 pan oven w/proof box base)
- UNI-MRO-8EP (8 pan oven w/proof box base)
- UNI-MRO-10EP (10 pan oven w/proof box base)
- UNI-MROSTAND (Stand for UNI-MRO-6E, UNI-MRO-8E or UNI-MRO-10E)



**Unisource Heavy Duty BRAVO™ Mini ROTATING
Rack Oven with High Capacity Steam System
and Optional Proofer
Model UNI-MRO-8E**



Follow the Leader™

THE UNISOURCE HEAVY DUTY BRAVO™ MINI-RACK ROTATING ELECTRIC OVEN

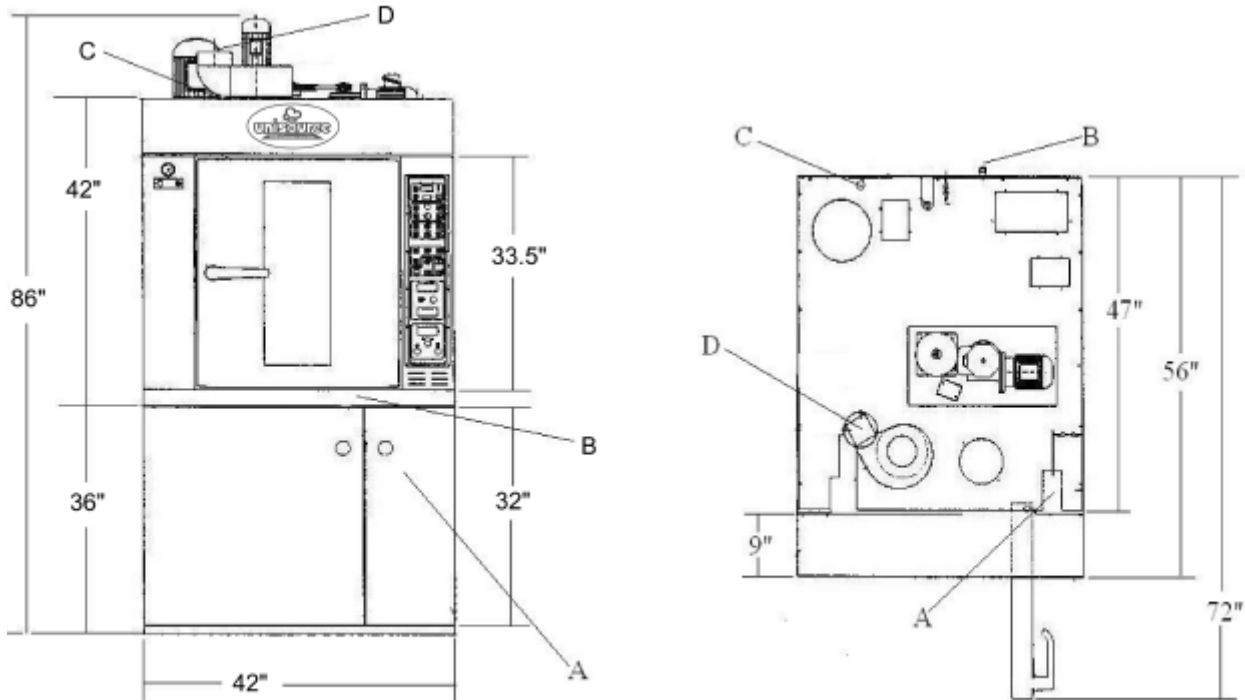

Above sketch shown with optional proof box base. If equipped with optional stand the dimensions will be the same.

A - Electrical 220/60/3 + ground @ 50 amps

Connection to be hardwired and located at 33" from floor/7" from right side of oven/41" from the rear of the oven. Wire to be dropped from the top of the oven and opening is provided to route wires as shown in "A" of top view.

NOTE: When providing the connection to the electrical box of the oven leave 36" of slack if unit is equipped with proof box base. This is allow the electrical panel to be moved forward for ease of service.

NOTE: Unit is supplied on casters if equipped with either stand or proofer base for ease of servicing and cleaning. Provide slack in electrical cable for ease of movement.

B - Drain 3/4" NPT connection

Connection is located 40" from floor/14" from right hand side of the unit at the rear. Drain is gravity feed and must be routed downward first then routed to floor drain. Oven is designed to be moved for servicing and cleaning and plumbing for drain installed in such a way to allow for oven movement. If steam will not be used in the oven the drain installation will not be necessary.

C - Water 1/2" NPT connection

Connection is located 88" from the floor/9" from left hand side of oven/4" from rear of oven. Oven if equipped with stand or proofer base is supplied with casters so the oven can be moved for servicing and cleaning. Water line must be flexible to allow for movement. Water pressure to the unit must be 20 to 50psi. If steam will not be used in the oven the water installation will not be necessary.

D - Oven vent 5" single wall vent to be routed outside the building with rain cap. Pipe to be a minimum of 24" above roof line or above parapet wall. Pipe diameter may be increased to 6" diameter. Oven is equipped with exhaust fan for hood.

NOTE: Servicing for the oven is accessed from the front/right hand side and rear of the oven. It is recommended for ease of movement that 12-24" around the perimeter of the oven is provided to allow for movement of the oven for servicing and cleaning.

Phone: (888) 443-8782 • Fax: (516) 681-0845 • email: unisource4@aol.com
56 Rockland Drive, Jericho NY 11753