



Follow the Leader™

Floral • Deli • Seafood • Meat • Bakery • Produce • Front End

## INTRODUCING THE UNISOURCE HEAVY DUTY **CUT-O-MATIC™ DONUT & BREAD SHEETERS**

The Unisource Production Table and Sheeter/Moulder combines the features of a production table with that of a bread moulder into one compact, **high efficiency** machine. The infeed conveyor belt carries the dough to the sheeting rollers where it is sheeted in **two gradual stages**.

For **Bread Moulding**, the dough passes to the heavy duty moulding assembly to make a variety of **bread**s, **hot dog rolls** and **bread sticks**. Two curling chains and three pressure plates are standard equipment.

When used as a **donut production** table for yeast fried foods, the dough is sheeted and cut with cutters automatically and uniformly. **Rotary cutters** are available for **donuts**, **bismarks**, **long johns**, **croissants** and **turnovers**. You can also sheet basic sweet dough, danish and puff pastry.

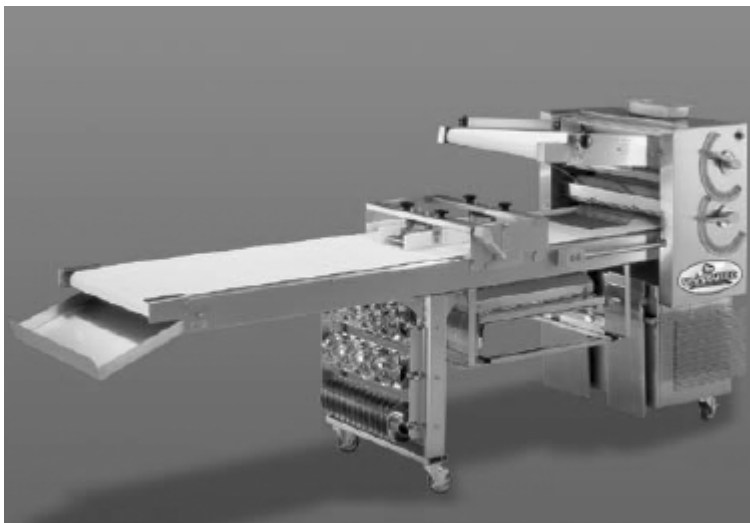

THE UNISOURCE **CUT-O-MATIC™** DONUT & BREAD SHEETER  
FOR AUTOMATIC PRODUCTION

### *Features:*

- Heavy Duty Stainless steel Construction
- Ease of clean-up promotes a sanitary environment
- Polyethylene dough guides, adjustable
- Two sets of cast nylon rollers - positive adjustment
- Nylon scrapers - easily removed for cleaning, no tools required
- Electronic Speed Control
- 2-ply polyester belt
- Three On/Off stations located on either side of machine
- 20' electrical cord
- Moulding assembly removable when not in use
- Cutter Storage Hanger for each cutter
- 1 Year Parts & Labor
- 24/7 Nationwide Service

### *Dimensions:*

- Belt Width - 20" or 24"
- Table Width - 23" or 27"
- Height - 55"
- Length - 116"

### *Options:*

- 14", 16" 18", 20" or 22" Pressure Plate For Bread Products
- Custom Table Lengths

Follow the Leader™

## INTRODUCING THE UNISOURCE HEAVY DUTY CUT-O-MATIC™ DONUT & BREAD SHEETERS

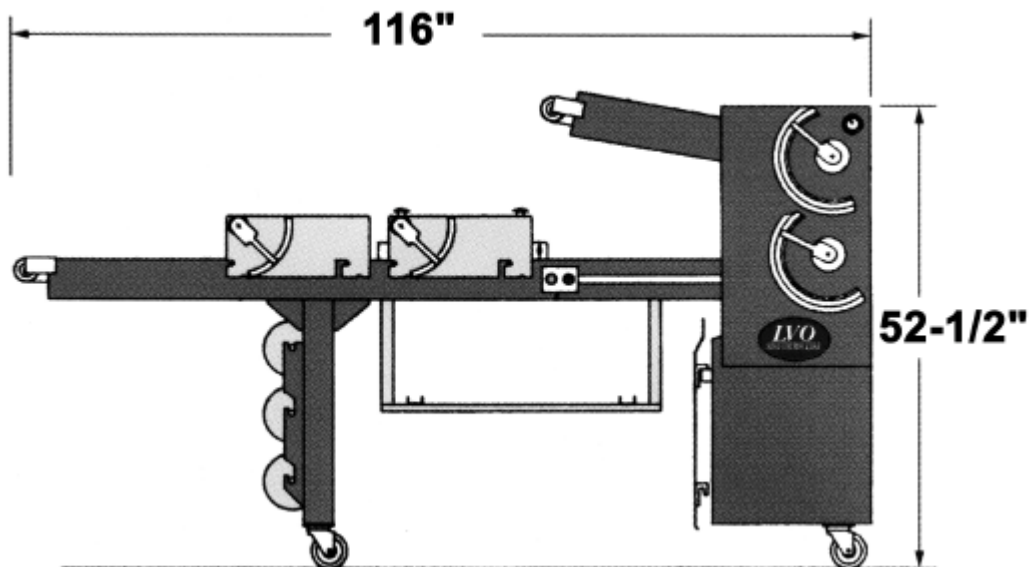
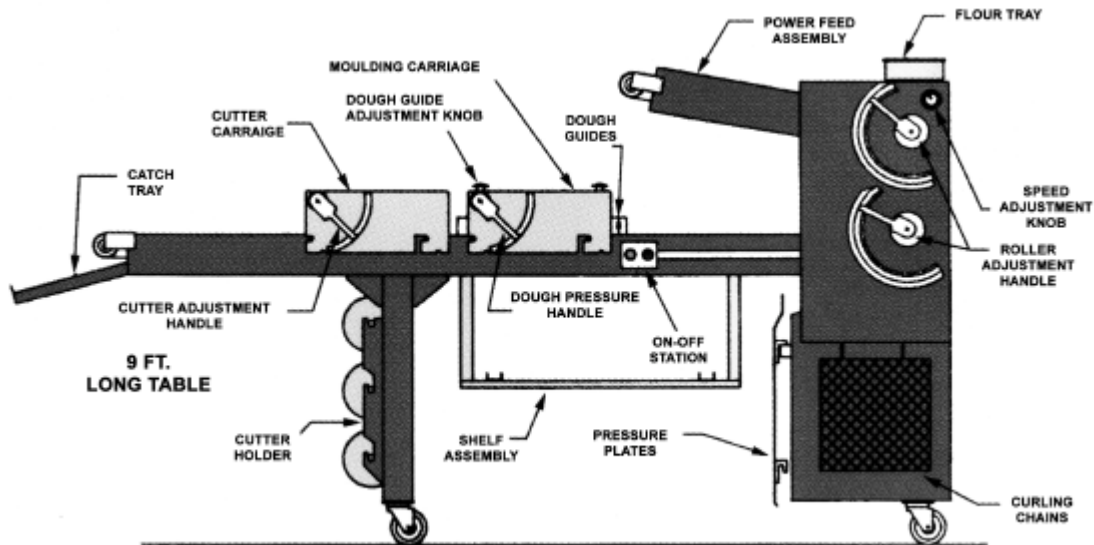

Double Feed	Overall Length	Overall Width	Overall Height
UNI-XR-31	116"	31-1/4"	55"
UNI-XR-35	116"	35-1/4"	55"

Phone: (888) 443-8782 • Fax: (516) 681-0845 • email: info@unisourcefoodequipment.com • www.unisourcefoodequipment.com  
56 Rockland Drive, Jericho NY 11753