



Follow the Leader™

Floral • Deli • Seafood • Meat • Bakery • Produce • Front End

INTRODUCING

THE UNISOURCE - SAFEWAY DIP TANK 5000™

Mobile Dip Cleaning System

Revolutionary system that cleans cookware without scrubbing for just pennies per item. It is safe, easy to use, and will dramatically improve kitchen appearance. In addition, it reduces labor hours, increases employee morale and uses a 100% bio-degradable solution!

- Bakery Pans
- Vent-a-hood filters
- Stainless steel items
- Plastic and glass pitchers
- Aluminum items
- Rotating pizza oven racks
- Burners and burner plates
- Trash cans
- Charcoal pit grates
- Broiler racks
- Light covers
- Rubber mats
- Coffee cups and porcelain bake ware
- Fryer baskets
- Grease filters



**THE UNISOURCE DIP TANK 5000
MOBILE DIP CLEANING SYSTEM**

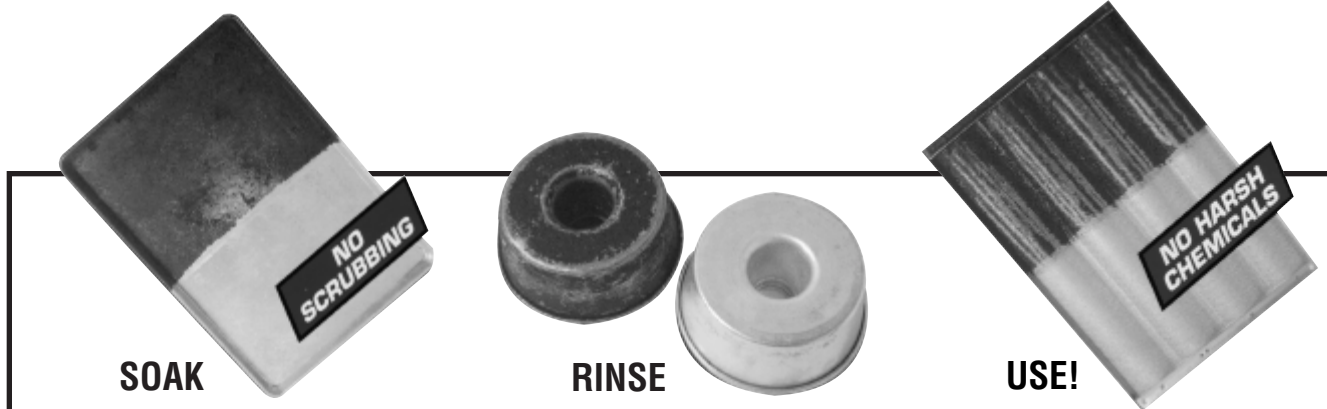

Is there any other process as safe and convenient in the market place today? The answer is NO!

Bakery managers, supermarket directors, restaurant managers, district and regional managers, health officials and more have been asked this question as part of our standard procedure. Simply choose any number related to commercial kitchens, including the health department, pick up the phone, and ask the question.

Saves Money!

Labor hours that range from 15 to 60 per month can be drastically reduced because scrubbing is no longer necessary. Just dip and rinse.

Safe

- The Dip Tank is 100% bio-degradable with pH level of 11.5.
- Unit has been certified as USDA "A1" for safe use on all food contact surfaces.
- Department of Transportation regulations do not

require any hazardous property warning labels on the containers.

- Skin and eye contact with the diluted solution is equal to that of soap; which can be rinsed away with water.
- The Dip Tank has no moving parts thus eliminating the chance of injury.

Labor Friendly

- Employee moral is increased because the tedious scrubbing process is eliminated.
- Items are easily lowered into the Dip Tank and when the process is complete they are simply pulled out, rinsed and ready to use.

Three Year Parts and Labor Warranty

The uncomplicated nature of the Dip Tank makes component problems highly unlikely and inexpensive.

Its dimensions make the Dip Tank unobtrusive

40" long - 23" wide - 39" high.

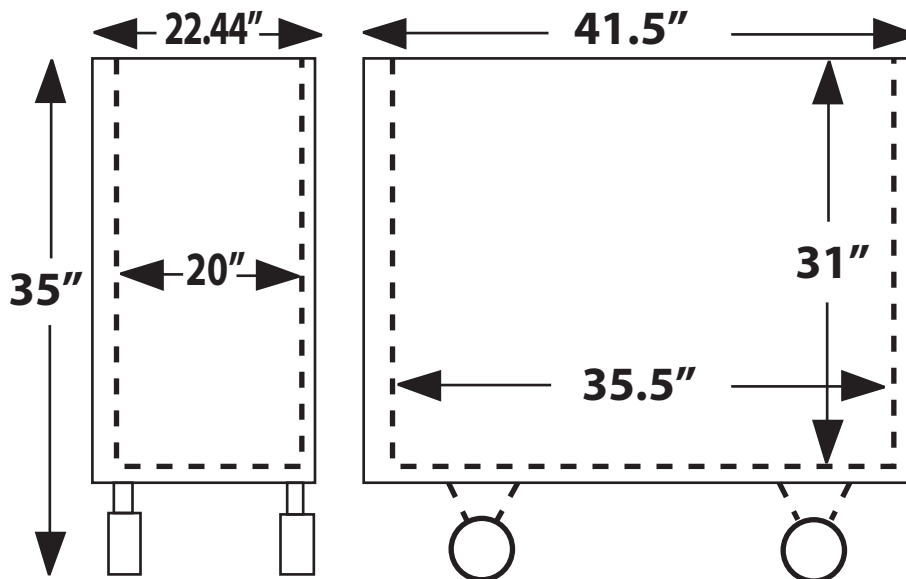

110V/10 AMP

95 Gal. Capacity Bottom Drain, NSF, UL

Shipping Weight 250 lbs.

MODEL 2500 AVAILABLE - 23" W x 37" D x 32" H. 45 Gallon