



Follow the Leader™

Floral • Deli • Seafood • Meat • Bakery • Produce • Front End

INTRODUCING UNISOURCE HEAVY DUTY *CRUSTY* BREAD SLICING MACHINE

Heavy Duty
Industrial
Slicer



Slices
Soft or Crusty
Breads!

- Made to slice thick, crusty Artisan Bread!
- Heavy Duty **industrial model**.
- Slices all types of bread thickness can be 10 mm, 13 mm and 16 mm according to your choice. Standard Model 1/2".
- All bread touching surfaces and knives are made of **stainless steel** and main body electrostatically painted.
- At the end of slicing process, the machine stops automatically. Easy to use, **no maintenance, easy cleaning** and small compact foot print.
- Manufactured as three phase or single phase motor power (110v, 60/1 phase), (208v/60/1 phase), (208v/60/3 phase)
- Semi automatic bread slicer
- **Heavy duty** slicing blades
- Crumb drawer for **E-Z cleaning**
- Slices soft or **heavy breads**
- **Includes** heavy duty castor wheels
- One year parts/labor warranty
- 24/7 Nationwide Service

Phone: (888) 443-8782 • Fax: (516) 681-0845 • email: info@unisourcefoodequipment.com • www.unisourcefoodequipment.com
56 Rockland Drive, Jericho NY 11753. Visit Our New showroom: 1505 Lincoln ave., Holbrook, NY 11741

Follow the Leader™



A safety bar on the loading side protects the operator when placing the loaves.

Raised shoe and high-strength caster with brake.

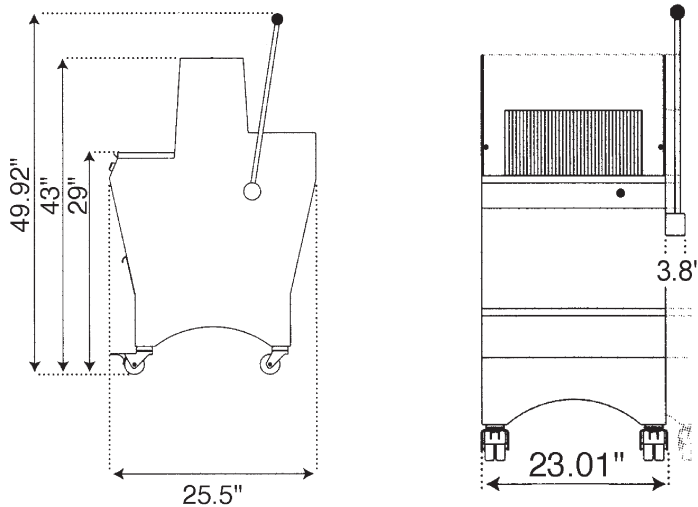

TECHNICAL SPECIFICATIONS

Semi-Automatic "Crusty"

Features

Max. loaf dimensions (L x w x h)

20.28" x 20" x 6.24"

Power output (in kW)

0.49

Net weight (in lbs.)

363 lbs.

Choice of

Slice thickness (in inches) 1.2" standard

10mm/13mm/16mm

Loaf height

6.24 Inches

Type of motor 220v or 110v

single- or 3-phase

Dimensions of Slicer

26.9 L x 25.5 D x 49.92 H