



Follow the Leader™

Floral • Deli • Seafood • Meat • Bakery • Produce • Front End

INTRODUCING THE UNISOURCE RUSTIC™ ROTARY HEARTH DECK OVENS

**GREAT FOR
ARTISAN BREAD
& PIZZA**



**VIRTUALLY
MAINTENANCE
FREE!**

Just imagine a deck oven that revolves in a circular motion for the true European Hearth Bake. Great for bread, rolls, pastries, pizza, and roasting of meat. This oven is used all over the world! USA, Japan, Canada, Greece, France, South Africa, Switzerland, Australia, Kuwait, New Caledonia, China, etc....

Features:

- All stainless steel front with attractive European rustic look!
- Revolving deck is easy to load product by simply turning the wheel. **NO OVEN LOADER IS NEEDED!**
- Virtually maintenance free
- Available in wood or gas fired
- Available sizes: 1.75m, 2.0m, 2.5m, 3.0m, 3.5m
- Built in Hearth steam System for crusty breads
- Energy efficient heating system save you money
- One year parts/labor warranty
- 24/7 nationwide service

Optional:

- Brick Face Front & Sides



BRICK FINISH

Follow the Leader™

INTRODUCING THE UNISOURCE RUSTIC™ ROTARY HEARTH DECK OVENS

O		A		B		C	
MILLIMETER	INCHES	MILLIMETER	INCHES	MILLIMETER	INCHES	MILLIMETER	INCHES
1.75	68.90	2.610	102.76	2.000	78.74	2.805	110.43
2.00	78.74	2.860	112.60			3.055	120.28
2.25	88.58	3.110	122.44			3.295	129.72
2.50	98.43	3.360	132.28			3.555	139.96
3.00	118.11	3.860	151.97			4.075	160.43
3.50	137.80	4.360	171.65			4.600	181.10

O		D		E		F	
MILLIMETER	INCHES	MILLIMETER	INCHES	MILLIMETER	INCHES	M2	SQ. INCHES
1.75	68.90	2.450	96.46	2.800	110.24	2.41	3.718.19
2.00	78.74					3.14	4.869.47
2.25	88.58					3.98	3.162.93
2.50	98.43					4.90	7.608.56
3.00	118.11					7.06	10.956.33
3.50	137.80					9.62	14.912.78

O		G		H		I		J
MILLIMETER	INCHES	MILLIMETER	INCHES	MILLIMETER	INCHES	KG.	POUNDS	BTUs
1.75	68.90	2.50	9.84	2.00	7.87	11.000	24.250	175,000
2.00	78.74					12.500	27.557	200,000
2.25	88.58					14.000	30.864	225,000
2.50	98.43					16.000	35.274	250,000
3.00	118.11					20.500	45.194	300,000
3.50	137.80					31.500	69.445	350,000

O	Diameter Platform
A	Outside Diameter
B	Outside Height
C	Outside Depth
D	Total Height
E	Minimal Service Height
F	Working Cooking Surface
G	Diameter Chimney Smokes
H	Diameter Chimney Steam
I	Total weight Installed Oven
J	BTU'S with Gas Burner

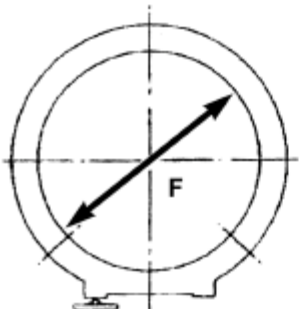
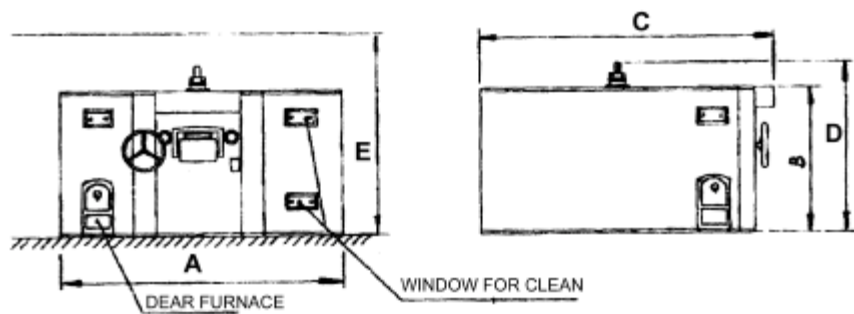

Phone: (888) 443-8782 • Fax: (516) 681-0845 • email: info@unisourcefoodequipment.com • www.unisourcefoodequipment.com
56 Rockland Drive, Jericho NY 11753